



SENIO

Alta Ceramica Faentina

CM10
5ª EDIZIONE

Le Perle monocottura modul system

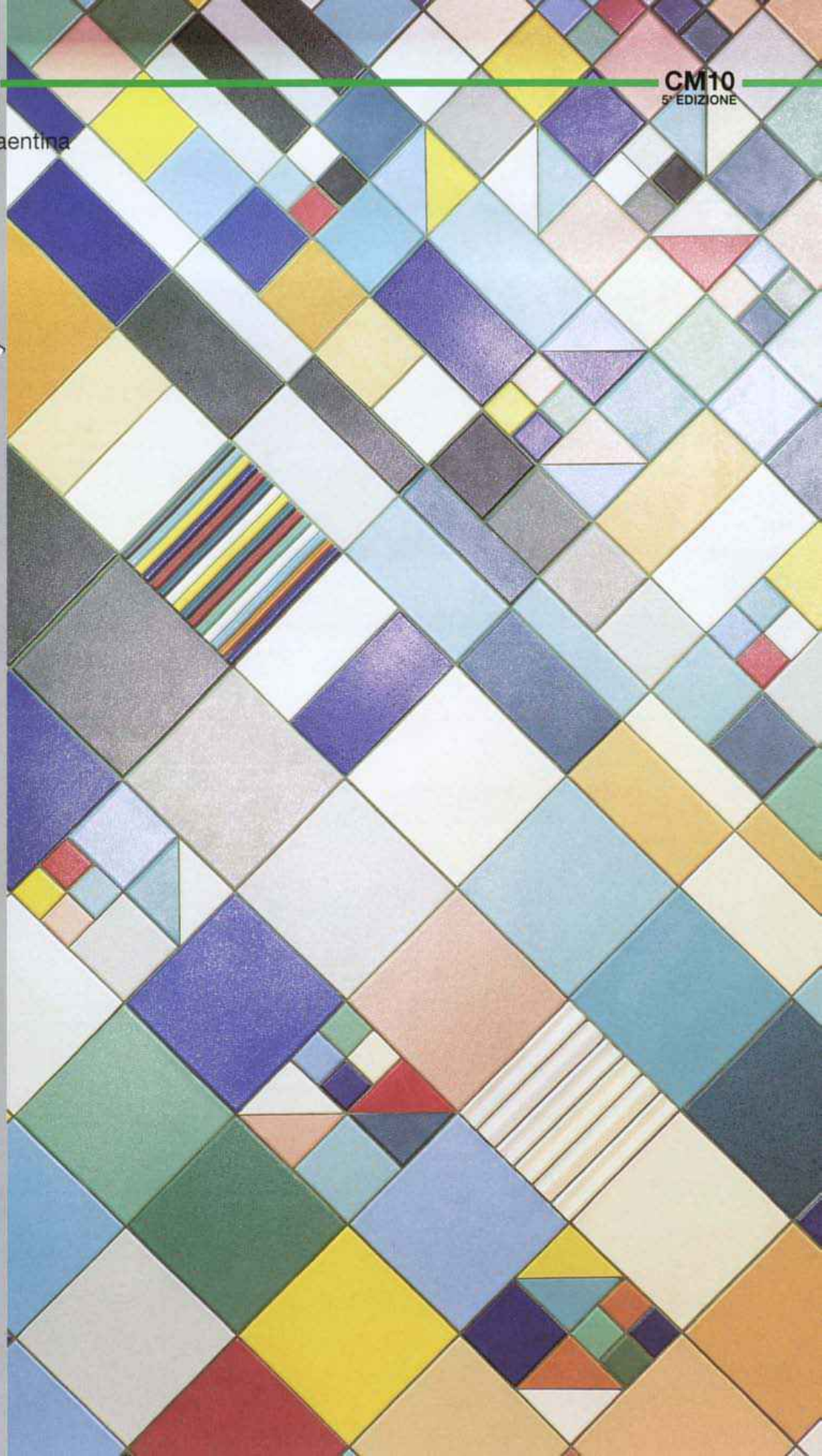



Le Perle

monocottura modul system

La linea di prodotti "Le Perle", già presente nella produzione Senio, è stata ulteriormente completata di finiture e pezzi speciali che consentono di eliminare spigoli e angoli prestandosi per ambienti pubblici e privati.

Si tratta di un prodotto tecnico a sistema modulare (con fuga di 3 mm) realizzato in 22 colori e 49 formati.

Sono stati aggiunti infine 5 formati Anti-Slip per ambienti umidi, per i quali si richiede una cospicua aderenza al camminamento.

"Le Perle", con posa a regola d'arte, esalta i propri requisiti tecnici elevando prestazioni anti shock termici e anti cavillo.

The current "Le Perle" Senio range has been completed with a wide range of special fittings and trims to cover edges and corners for private and public settings.

It is a technical range available in 22 colours and 49 totally modular sizes (3 mm joint).

5 Anti-Slip colours have been added for covering areas in humid environments that require a greater adherence.

If properly fixed "Le Perle" guarantee the highest resistance to crazing and to thermal shocks.



Die Serie "Le Perle", die im Senio-Sortiment schon vorher anwesend war, ist durch eine weitere Reihe von Vollendungs- und Sonderstücken ergänzt worden, die ermöglichen, in einem verfliesen öffentlichen oder privaten Raum alle scharfe Kanten und Ecken abzurunden und entfernen.

Das ist ein technischer Produkt in Modulsystem - d.h. mit 3 mm. Fuge verlegt - in 22 Farben und 49 Formaten.

Fünf weitere Formate mit RUTSCHFESTIGKEIT hat man für die Benutzung in feuchten Räumen extra produziert, wo eine grössere Haftung auf Boden notwendig ist.

Die "Perle" sind durch wichtige technische Eigenschaften gekennzeichnet und - bei fachgerechter Verlegung - im Fall von Thermoschock und Haarrisse garantiert.

Une serie de pièces spéciales et de finitions complète la gamme des produits "Le Perle" qui est déjà présente dans la collection Senio depuis quelque temps.

Ces pièces ont pour fonction d'éliminer les arêtes vives et les angles dans tous les lieux publics et d'habitation.

"Le Perle" est une gamme technique, modulaire (avec joints de 3 mm.) qui a été réalisée en 22 couleurs et dans 49 différents formats.

5 formats anté-glisse ont été ajoutés à cette serie. Ces carreaux peuvent être utilisés dans des endroits humides qui nécessitent d'une meilleure adhérence au sol.

La gamme "Le Perle" offre des performances techniques d'un très haut niveau et elle est garantie si la pose des carreaux est réalisée selon les règles de l'art.

22 colori in 49 formati!

22 colours in 49 sizes!

J330 BIANCO 20x20 - 10x10 ROSA ANTICO E ROSA LAMPONE - PEZZI SPECIALI

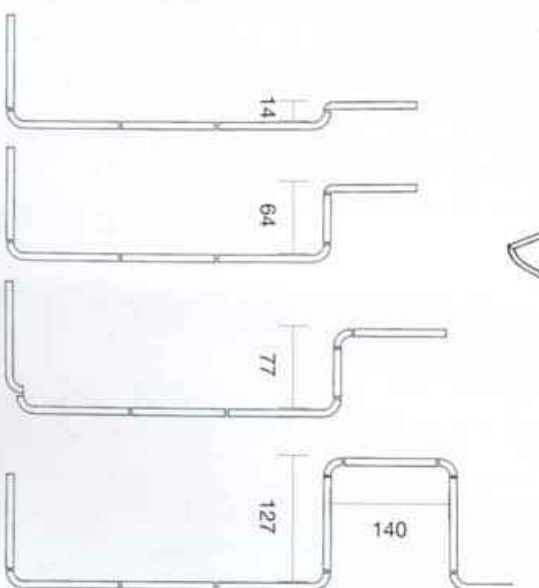

COVE BASE ORIZZONTALE

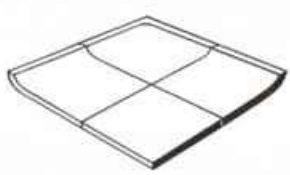

ANGOLO COVE BASE

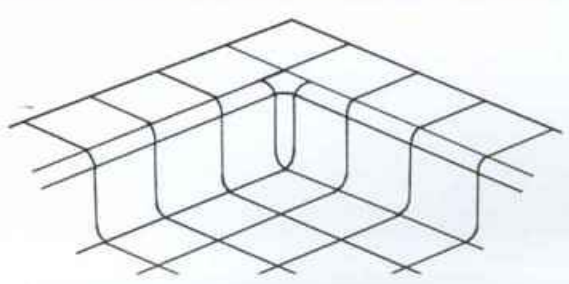

COVE BASE VERTICALE

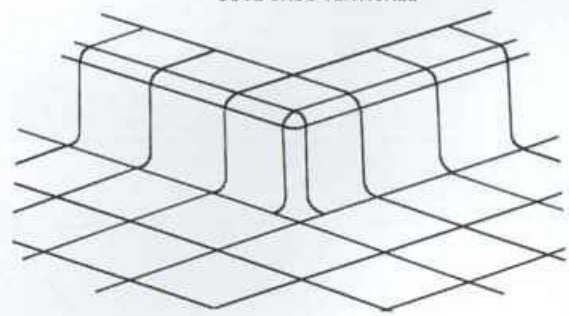

PROPOSTE MODULARI cm 5-10-20

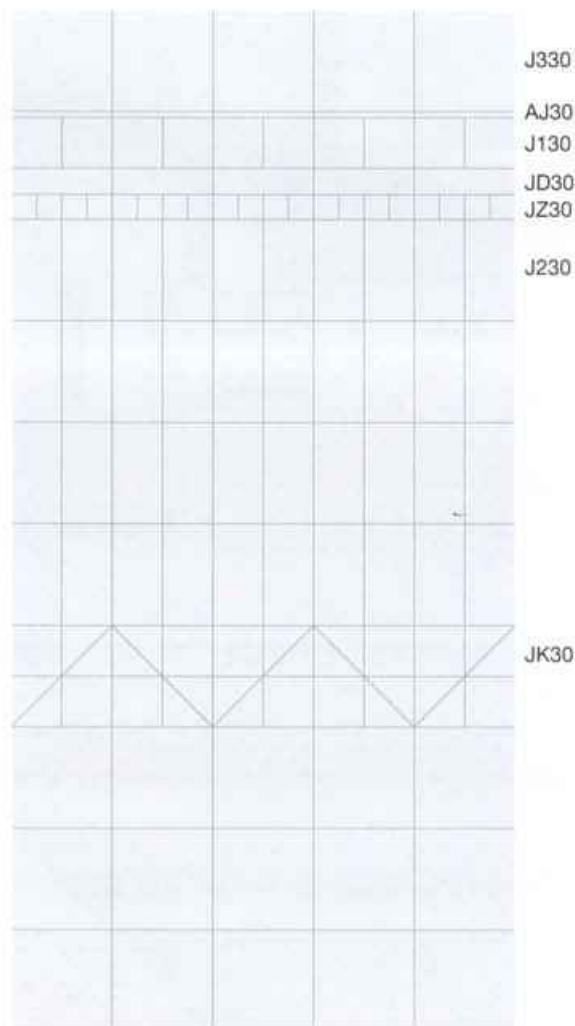

5036 PS PERLE BIANCO

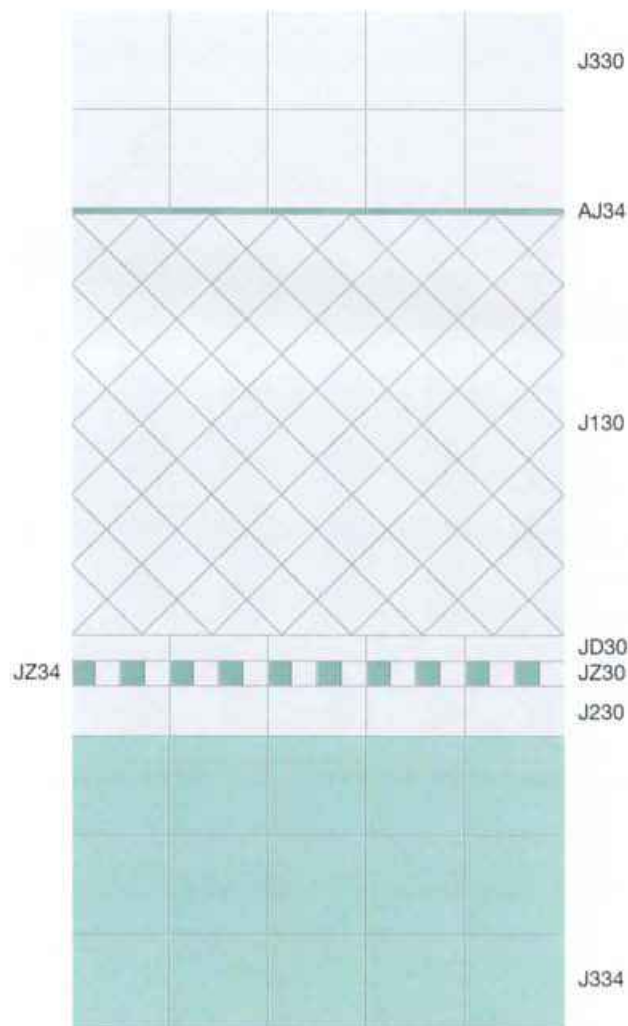

5040 PS PERLE BIANCO / ACQUAMARINA

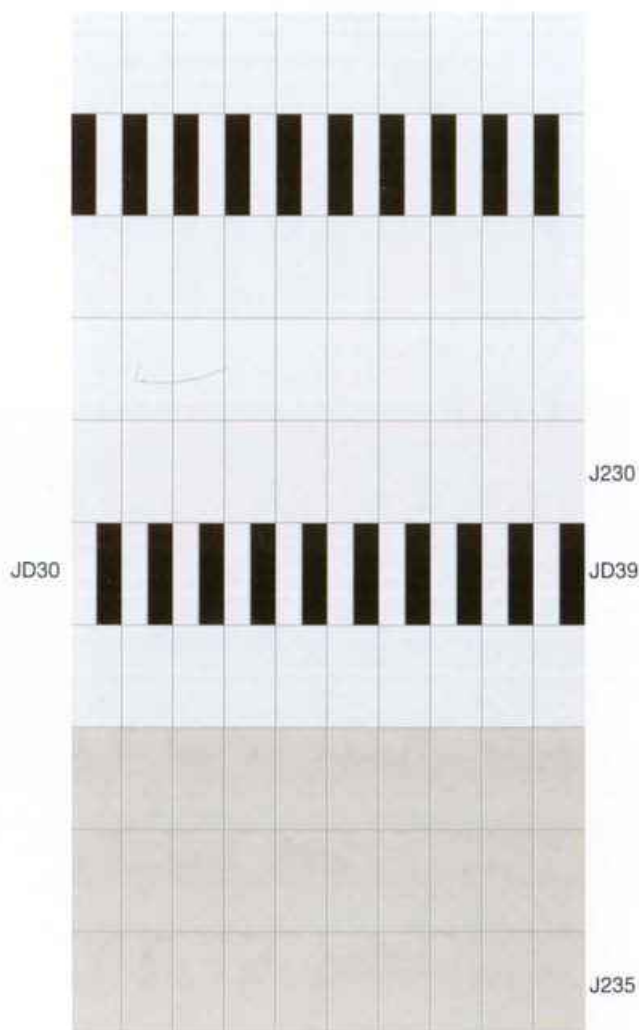

5032 PS PERLE GRIGIO

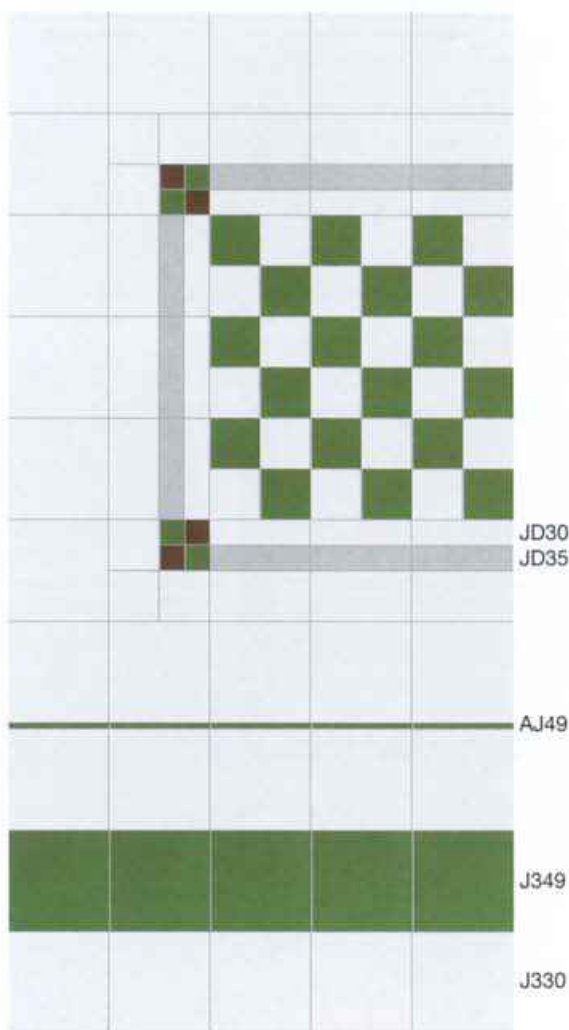

5033 PS PERLE VERDE

PROPOSTE MODULARI cm 5-10-20

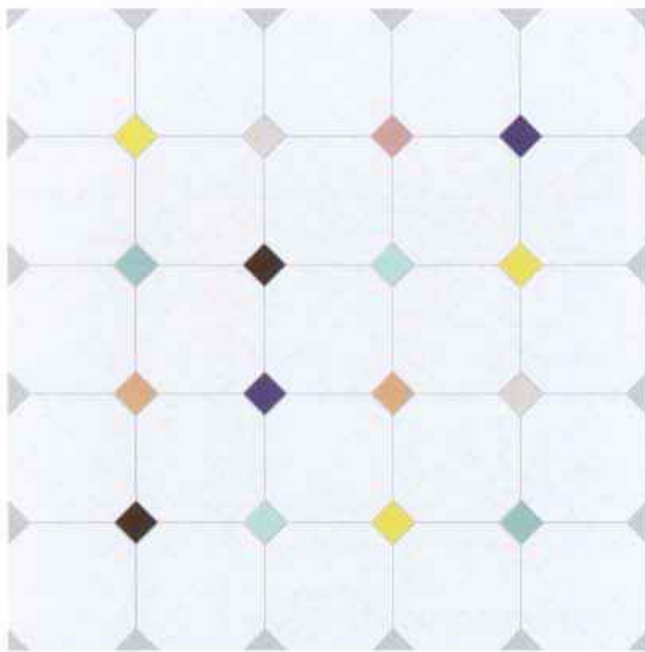

Pannello 5 - OTTAGONO J430 - COLORI MISTI



Pannello 6 - J330 - JD30 - JD35 - JD39 - JD34

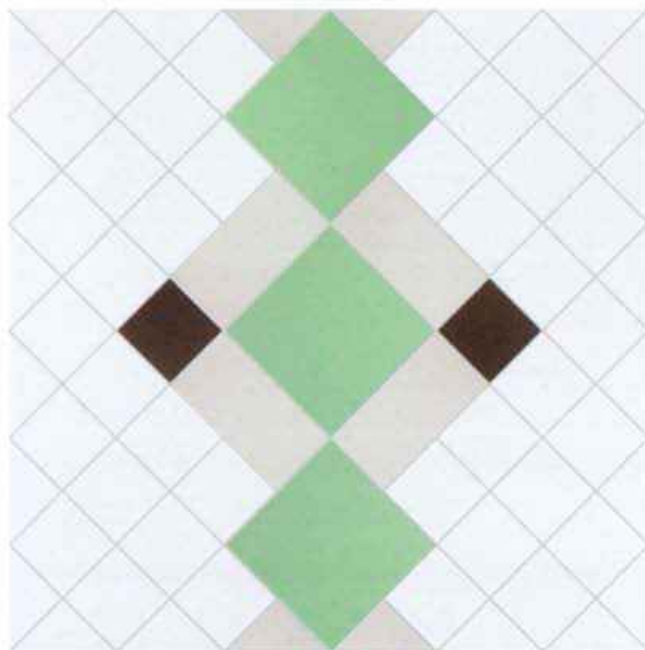

Pannello 7 - J342 - J130 - J235 - J139

J330 JZ50 JZ30 J145 J325

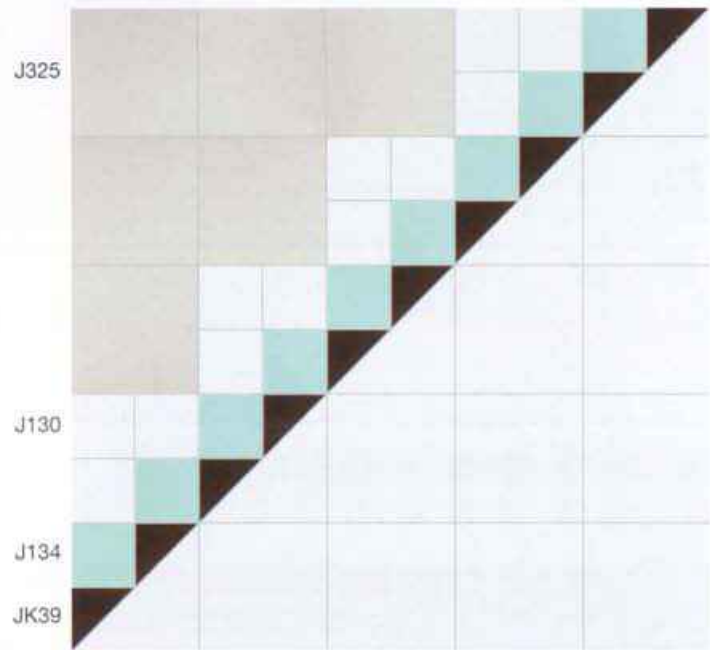

Pannello 8

J330

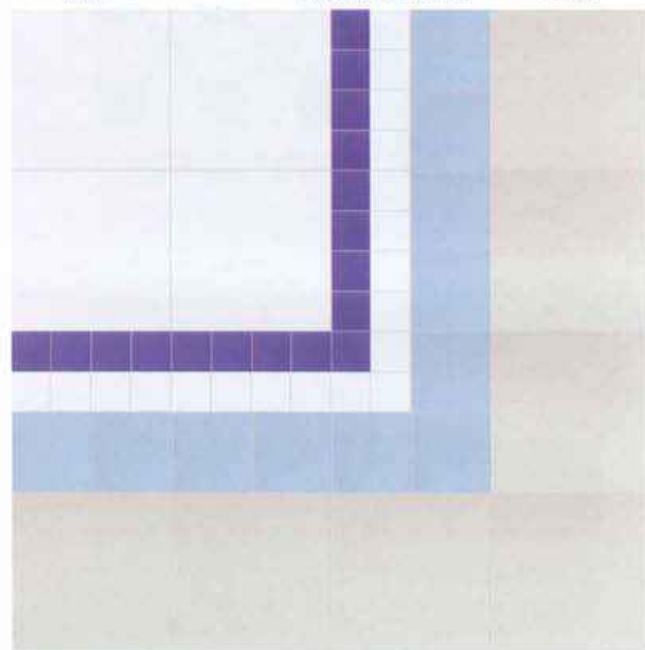

Pannello 9

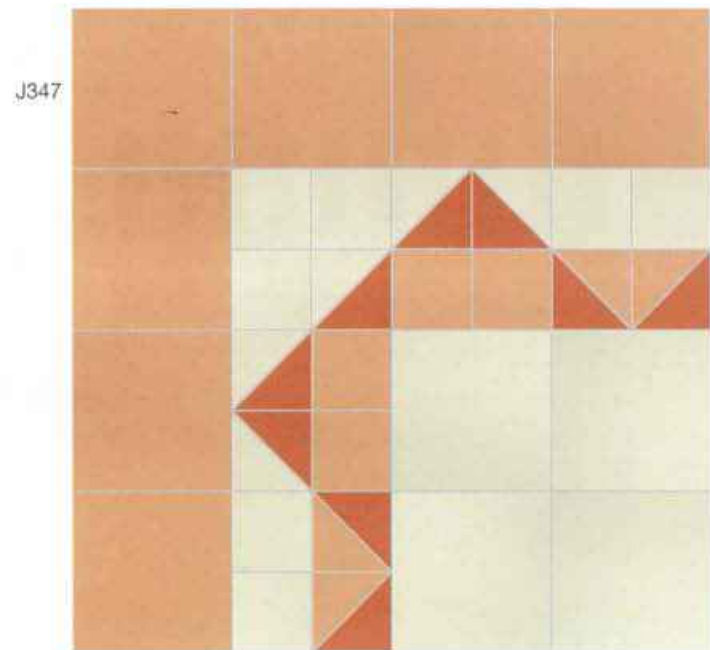

Pannello 10 - J130 - JK47 - JK27

J330

J337

PROPOSTE MODULARI cm 5-10-20

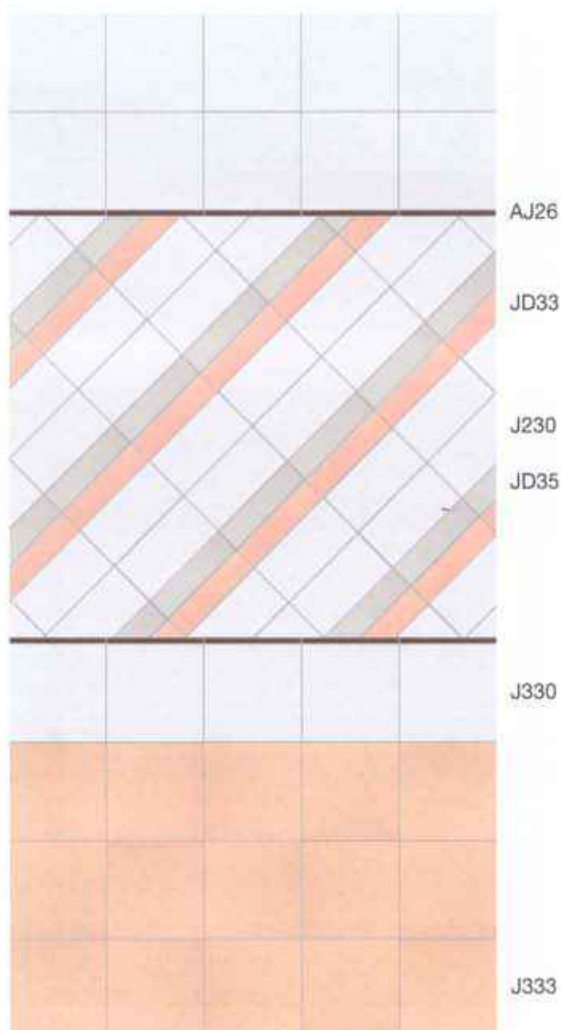

5034 PS PERLE ROSA PESCA

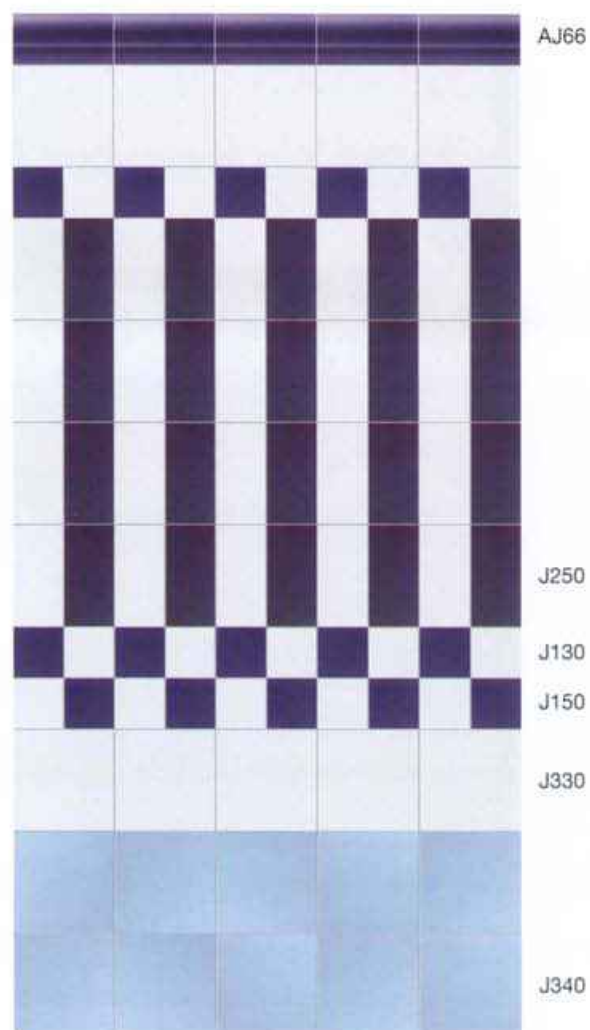

5035 PS PERLE BLU



5036 PS PERLE ACCUMARUM

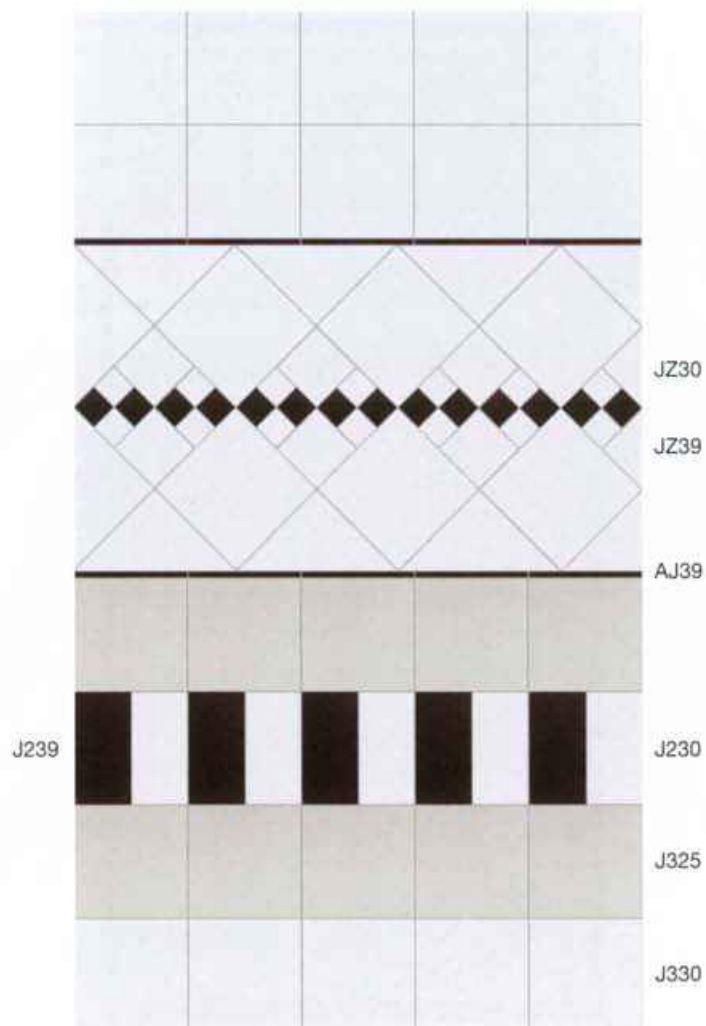

5038 PS PERLE CRICIO

PROPOSTE MODULARI cm 5-10-20

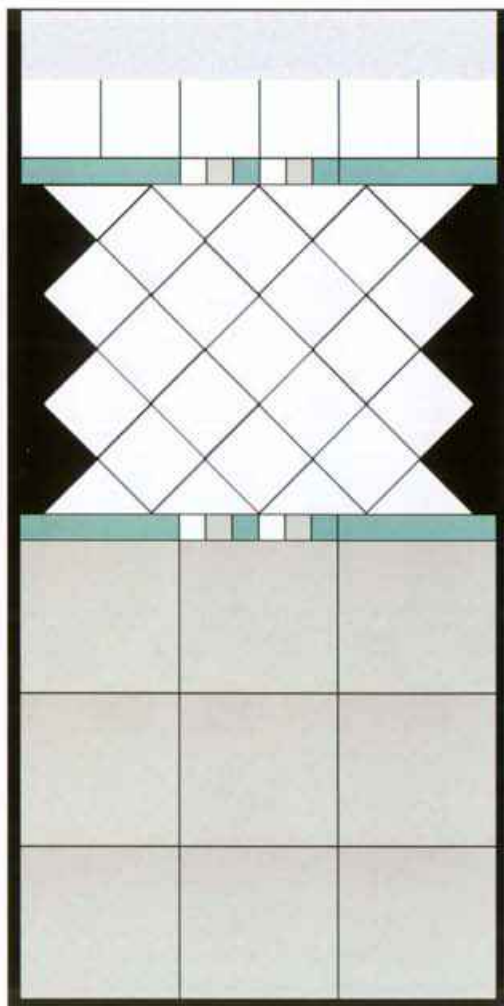

J030

J235

J025

5101 PS GRIGIO TURCHESE

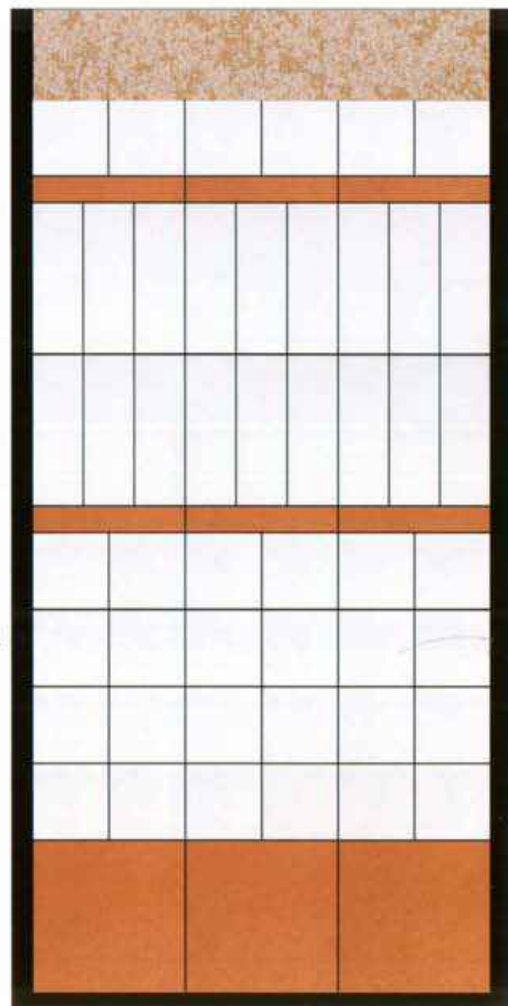

J1130

J1227

JZ34

J030

J1027

5103 PS BIANCO COTTO

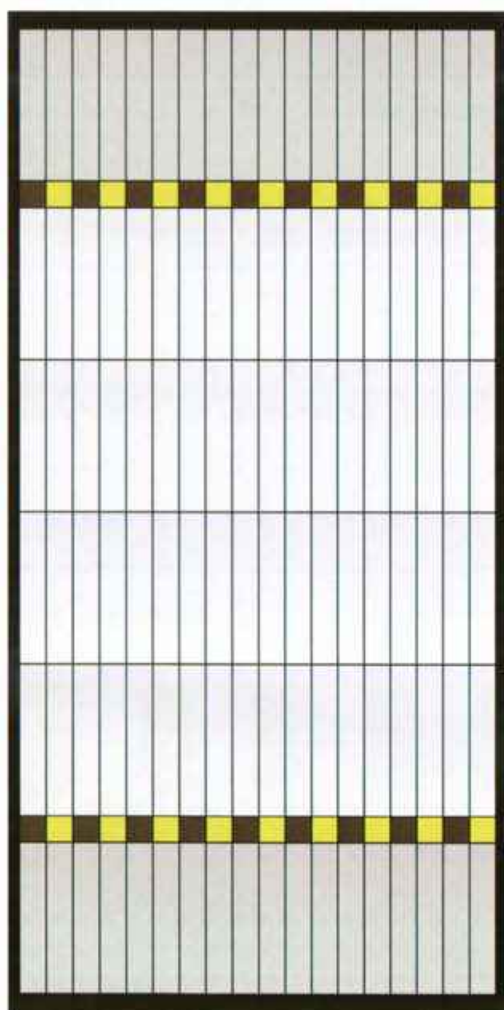

J1125

JZ28

J1230

JZ39

5102 PS GRIGIO GIALLO (PARETI CURVE)

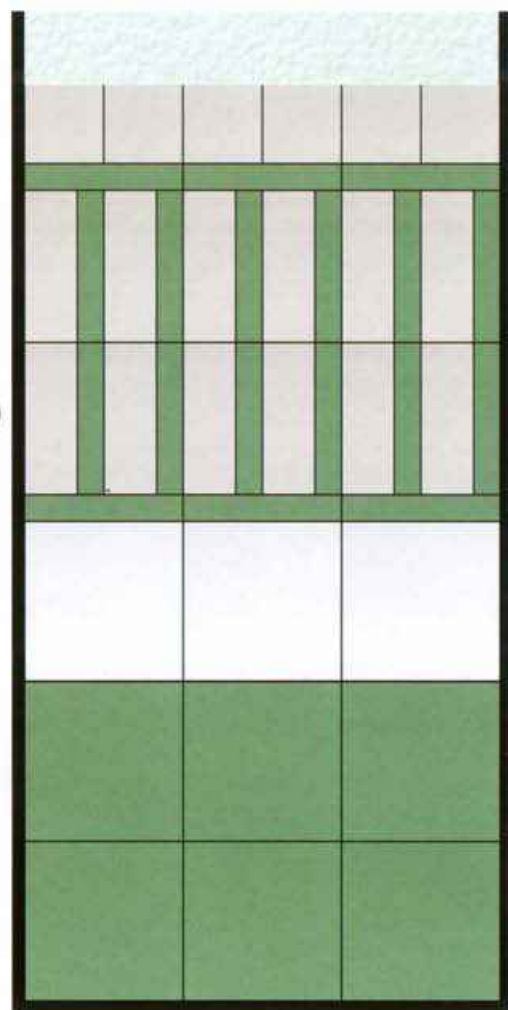

J030

J1249

J1030

J1130

J1049

5104 PS BIANCO VERDE MENTA





La modularità dei formati consente di creare geometrie colorate mantenendo una fuga costante di 3 mm

The modularity of the sizes let you create coloured geometrical patterns keeping a constant joint of 3.00 mm

20x20



9,85x9,85

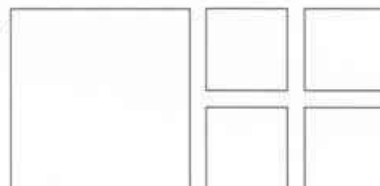

4,85x4,85



Ambientazione virtuale realizzata con il nostro programma grafico **ATDS** (Automatic Tiles Display System)

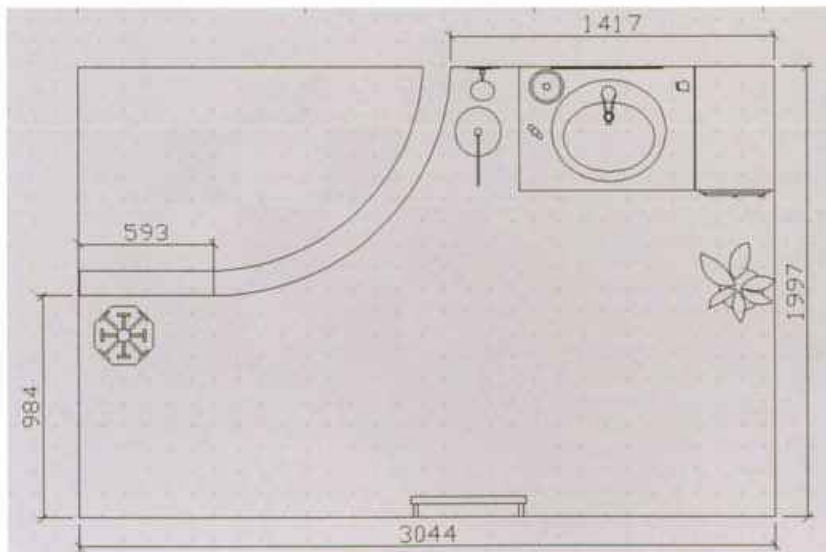

PAVIMENTO J1046 - Bleu elettrico 30x30
RIVESTIMENTO

- J1230** - bianco 4,85x30
- J1225** - grigio chiaro 4,85x30
- JZ28** - giallo 4,85x4,85
- JZ46** - bleu elettrico 4,85x4,85
- J1030** - bianco 30x30
- J130** - bianco 9,85x9,85
- J146** - bleu elettrico 9,85x9,85
- J128** - giallo 9,85x9,85
- CJ01** - bead esterno 2,85x9,85
- CJ03** - bead interno 2,85x9,85
- AJ02** - beak esterno 2,5x2,5



LE PERLE: J346 BLEU ELETTRICO - J345 CELESTE



Pannello 11

J342

J337

J149

J130

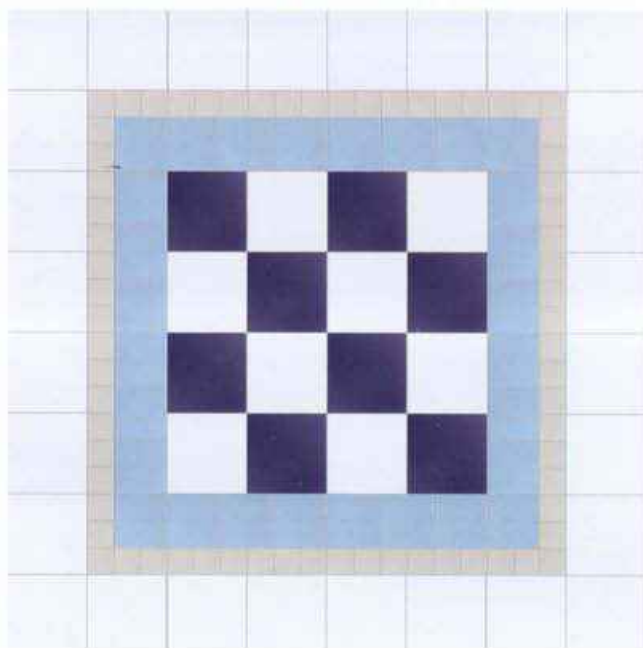

Pannello 12 - J030 - JZ25 - J145 - J046 - (4,85x4,85-9,85x9,85-15x15)

NAUTILUS

decori 9,85x9,85



JM111 NAUTILUS



JM112 FELCE



JM113 STELLA



JM114 RAMELLO



JM115 NAUTILUS LISTELLO 6x20

Ogni decoro della serie "Nautilus" comprende tutti i colori della linea "perle" per cui può essere inserito in tutti i fondi colorati oltre al bianco

Every decor of the "Nautilus" serie contains all colours of the "perle" range so that it can be used with all the colored field tiles besides the white

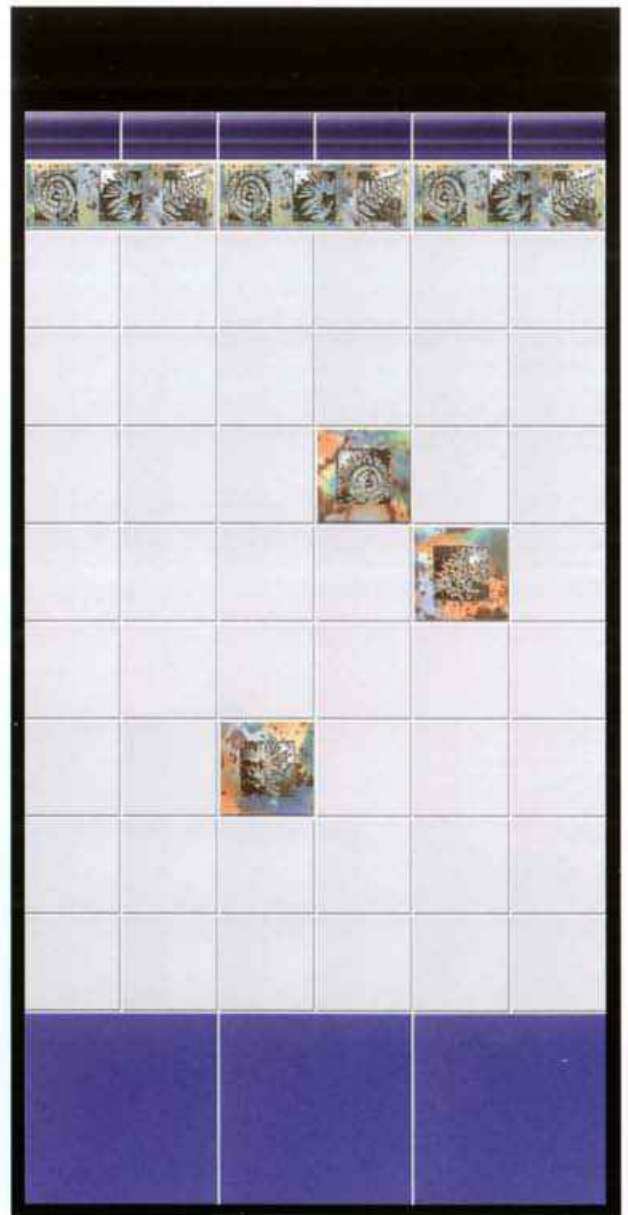

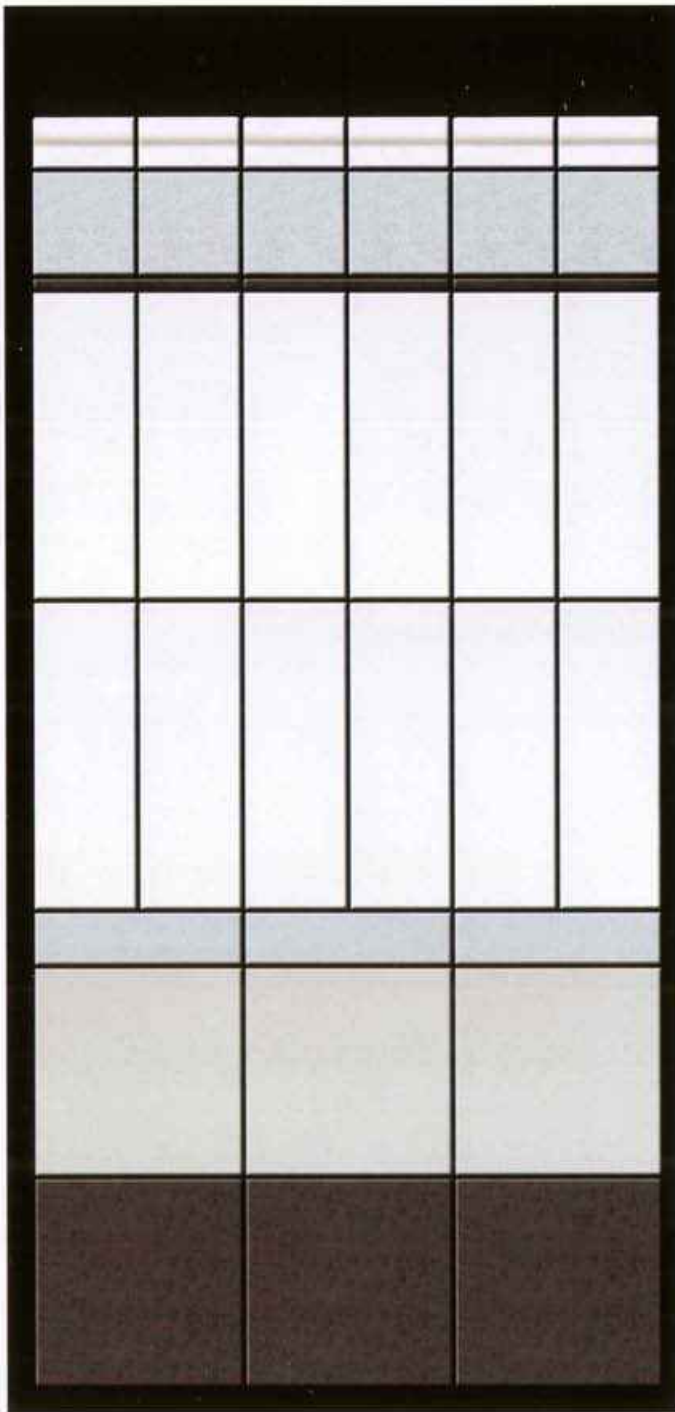

5030 RM GRIGIO/ANTRACITE

65x130

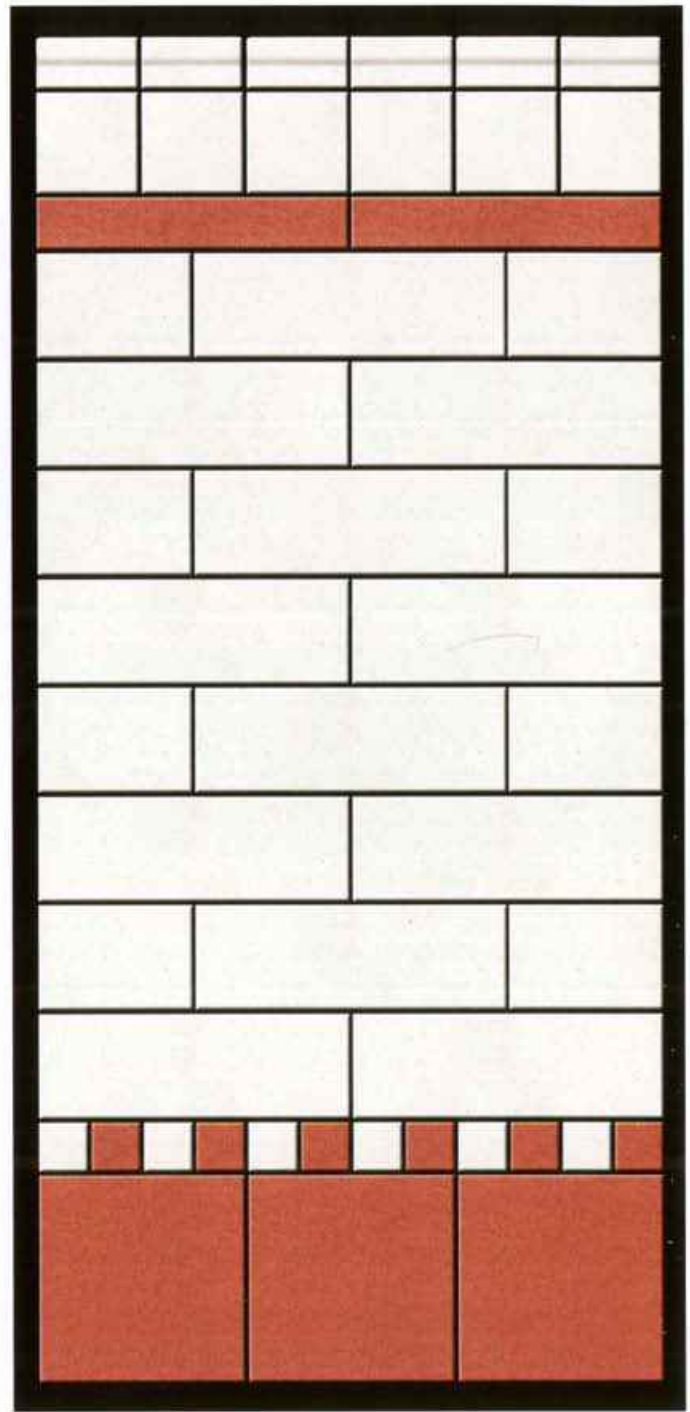

5031 RM PANNA/COTTO

65x130

J1149



J1239

J1228

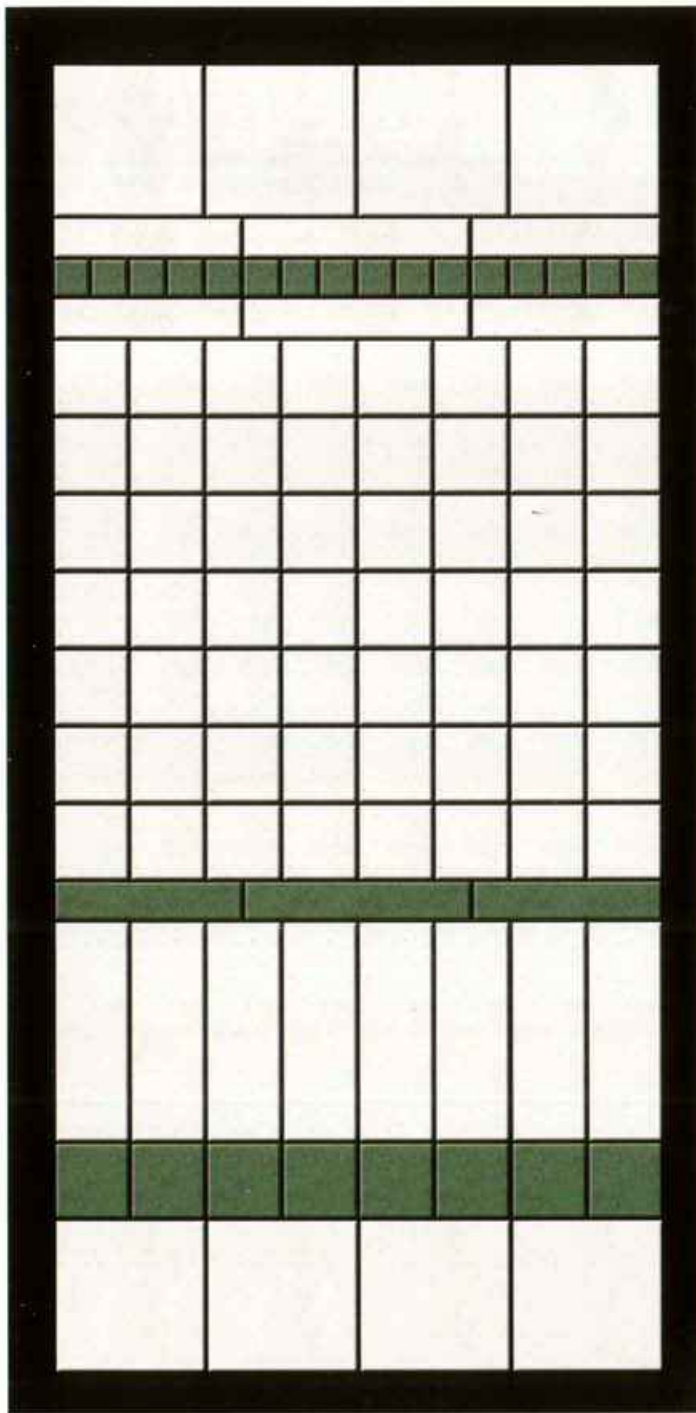

5029 RG PANNA/VERDE

96x182

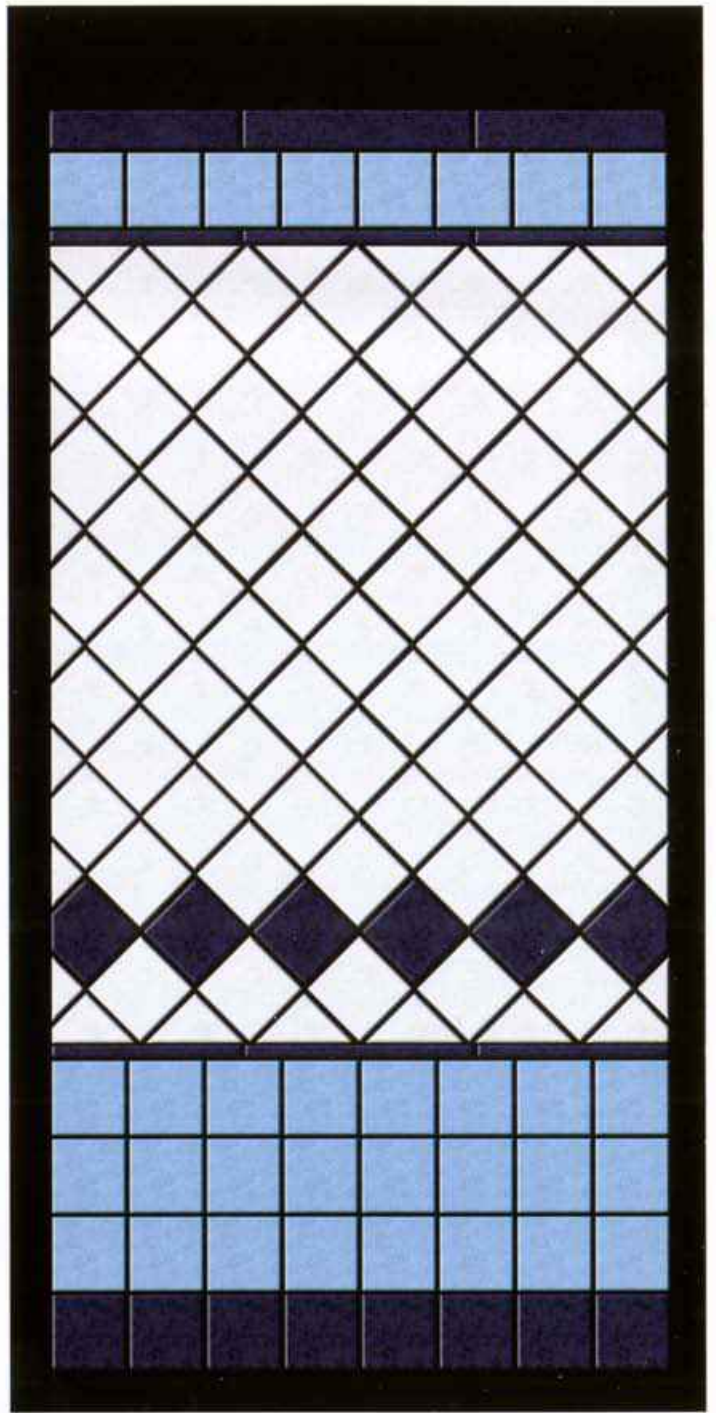

5028 RG BIANCO/BLEU

96x182



MONOCOTTURA

FORMATI COLORI															
	30x30	20x20	15x15	9,85x9,85	9,85x30	4,85x30	TR. 9,85	9,85x20	4,85x20	4,85x4,85	OTTAGONO 20x20	BULLNOSE 9,85x9,85	CORNER 9,85x9,85	COV BASE BATTISC. 10x20	COVE BASE 9,85x20
BIANCO	J1030	J330	J030	J130*	J1130	J1230	JK30	J230	JD30	JZ30	J430	JB30	JC30	JA13	JA14
PANNA	J1029	J329	J029	J129*	J1129	J1229	JK29	J229	JD29	JZ29	J429	JB29	JC29	JA17	JA18
PERGAMON															
BEIGE		J332													
GRIGIO CHIARO	J1025	J325	J025	J125	J1125	J1225	JK25	J235	JD35	JZ25		JB25	JC25		
GRIGIO MEDIO		J337	J037	J137			JK37			JZ37					
GRIGIO SCURO		J338	J038	J138			JK38			JZ38					
GRIGIO ANTRACITE	J1039	J339	J039	J139	J1139	J1239	JK39	J239	JD39	JZ39					
ACQUAMARINA		J334	J034	J134			JK34	J234	JD34	JZ34		JB34	JC34		
TURCHESE	J1035	J335	J035	J135	J1135	J1235	JK35			JZ35					
PETROLIO		J336	J036	J136			JK36			JZ36					
AZZURRO		J340													
CELESTE		J345	J045	J145			JK45			JZ45		JB45	JC45		
BLEU ELETTRICO	J1046	J346	J046	J146	J1146	J1246	JK46			JZ46					
BLEU NOTTE	J1050	J350	J050	J150	J1150	J1250	JK50	J250	JD50	JZ50					
VERDE PRATO		J342		J142			JK42			JZ42					
VERDE MENTA	J1049	J349	J049	J149	J1149	J1249	JK49			JZ49					
ROSA ANTICO		J341	J041	J141			JK41			JZ41					
LAMPONE		J326		J126			JK26			JZ26					
ROSA PESCA		J333	J033	J133			JK33	J233	JD33	JZ33					
GIALLO LIMONE	J1028	J328	J028	J128	J1128	J1228	JK28			JZ28					
TERRACOTTA		J347	J047	J147			JK47	J247	JD47	JZ47		JB47	JC47		
COTTO	J1027	J327	J027	J127	J1127	J1227	JK27			JZ27					

* NJ130 bianco 9,85x9,85 su rete / on net

* NJ129 panna 9,85x9,85 su rete / on net

MONOCOTTURA

BULLNOSE
9,85x9,85

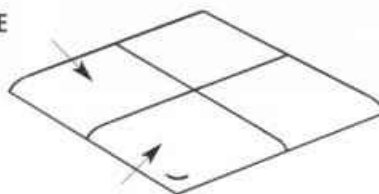

CORNER 9,85x9,85



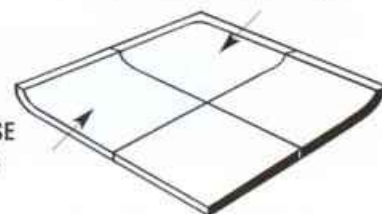



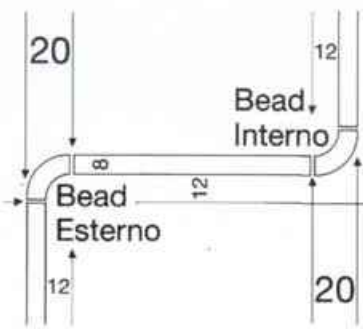
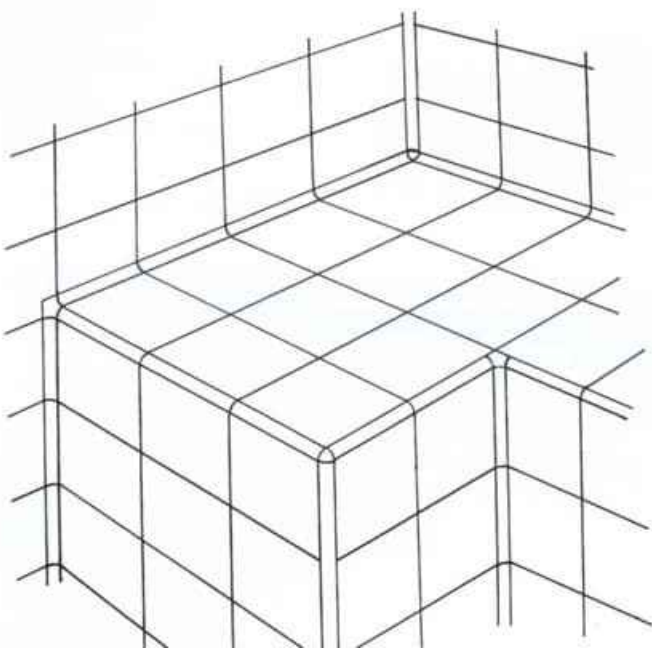







ANGOLO COVE BASE 9,85x9,85



COVE BASE
9,85x9,85



MONOCOTTURA

FORMATI COLORI															
	COVE BASE 9,85x9,85	ANGOLO COVE BASE 9,85x9,85	PIE' D'OCA X BATTIS. 2,5x10	LANCIA X BATTIS. 2,5x10	PIE' D'OCA ESTERNO 2,5x9,85	LANCIA INTERNO 2,5x9,85	BEAD EST. 2,5x20	BEAK EST. 2,5x2,5	BEAD INT. 2,5x20	BEAK INT. 2,5x2,5	BEAD EST. 2,5x9,85	PIE' D'OCA EST. X BEAD 2,5x3,0	BEAD INT. 2,5x9,85	PIE' D'OCA INT. X BEAD 2,5x3,0	BATTISCOPIA 7,5x30
BIANCO	JA15	JA16	AJ23	AJ24	AJ19	AJ22	AJ01	AJ02	AJ03	AJ04	CJ01	CJ02	CJ03	CJ04	JH30
PANNA	JA51	JA52			AJ81	AJ82	AJ05	AJ06	AJ07	AJ08	CJ05	CJ06	CJ07		JH29
PERGAMON															
BEIGE							BJ09	BJ10	BJ11	BJ12		CJ10			
GRIGIO CHIARO	JA61	JA62			AJ83	AJ84	BJ13	BJ14	BJ15	BJ16	CJ13	CJ14	CJ15		JH25
GRIGIO MEDIO							BJ17	BJ18	BJ19	BJ20	CJ17	CJ18	CJ19		
GRIGIO SCURO							BJ21	BJ22	BJ23	BJ24	CJ21	CJ22	CJ23		
GRIGIO ANTRACITE							BJ25	BJ26	BJ27	BJ28	CJ25	CJ26	CJ27		
ACQUAMARINA	JA71	JA72					BJ29	BJ30	BJ31	BJ32	CJ29	CJ30	CJ31		
TURCHESE							BJ33	BJ34	BJ35	BJ36	CJ33	CJ34	CJ35		
PETROLIO							BJ37	BJ38	BJ39	BJ40	CJ37	CJ38	CJ39		
AZZURRO							BJ41	BJ42	BJ43	BJ44		CJ42			
CELESTE	JA81	JA82					BJ45	BJ46	BJ47	BJ48	CJ45	CJ46	CJ47		
BLEU ELETTRICO							BJ49	BJ50	BJ51	BJ52		CJ50			
BLEU NOTTE							BJ53	BJ54	BJ55	BJ56	CJ53	CJ54	CJ55		JH50
VERDE PRATO							BJ57	BJ58	BJ59	BJ60	CJ57	CJ58	CJ59		
VERDE MENTA							BJ61	BJ62	BJ63	BJ64	CJ61	CJ62	CJ63		
ROSA ANTICO							BJ65	BJ66	BJ67	BJ68	CJ65	CJ66	CJ67		
LAMPONE							BJ69	BJ70	BJ71	BJ72	CJ69	CJ70	CJ71		
ROSA PESCA							BJ73	BJ74	BJ75	BJ76	CJ73	CJ74	CJ75		
GIALLO LIMONE							BJ77	BJ78	BJ79	BJ80	CJ77	CJ78	CJ79		
TERRACOTTA	JA91	JA92					BJ81	BJ82	BJ83	BJ84	CJ81	CJ82	CJ83		
COTTO							BJ85	BJ86	BJ87	BJ88	CJ85	CJ86	CJ87		JH27

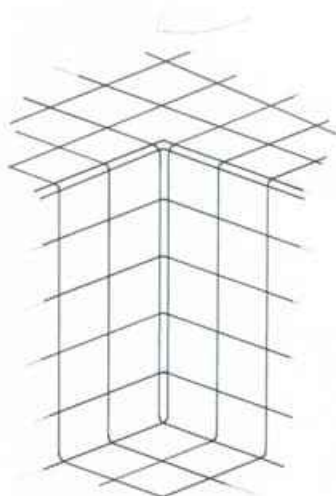

ANGOLO INTERNO

LANCIA INTERNA
PIE' D'OCA INTERNO
BEAD INTERNO
BEAD ESTERNO

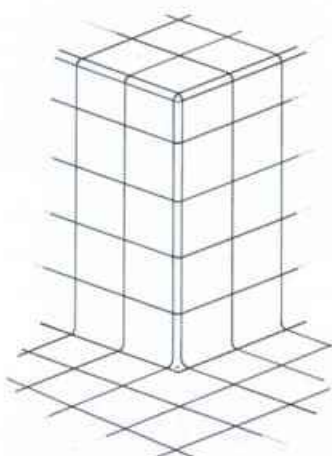

ANGOLO ESTERNO

PIE' D'OCA ESTERNO
BEAK ESTERNO
BEAD ESTERNO

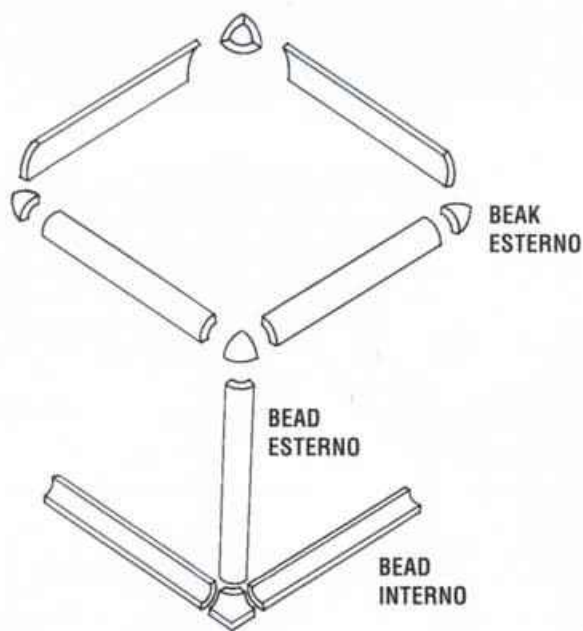

PIE' D'OCA ESTERNO



ANTISLIP

PEZZI SPECIALI PER INTERNI IN BICOTTURA TRADIZIONALE

FORMATI COLORI							
	9,85x9,85	BULLNOSE 9,85x9,85	CORNER 9,85x9,85	COVE BASE 9,85x9,85	ANGOLO COVE BASE 9,85x9,85	15x15	9,85x20
BIANCO	JR01*	JR02	JR03	JR04	JR05	JR40	JR16
PANNA	JR06	JR07	JR08	JR09	JR10		JR17
PERGAMON							
BEIGE							
GRIGIO CHIARO	JR11*					JR45	JR18
GRIGIO MEDIO							
GRIGIO SCURO							
GRIGIO ANTRACITE							
ACQUAMARINA	JR12						
TURCHESE							
PETROLIO							
AZZURRO							
CELESTE	JR13						
BLEU ELETTRICO							
BLEU NOTTE	JR14						
VERDE PRATO							
VERDE MENTA							
ROSA ANTICO							
LAMPONE							
ROSA PESCA							
GIALLO LIMONE							
TERRACOTTA	JR15						
COTTO							

MATITA 1x20	MATITA 1,5x25	MATITA 1,5x30	MATITA 1,5x33,3	QUARTINO 1x20	UNGHETTA QUARTINO 1x1x1	PIE' D'OCA QUARTINO 1x1	CAPITELLO 4x9,85	ANGOLO CAPITELLO 4x4	SPIGOLO CAPITELLO 2x4
AJ30	CJ91	BJ91	AJ91	DJ01	DJ02	DJ03	AJ51	AJ52	AJ53
AJ29				DJ04	DJ05		AJ54	AJ55	AJ56
AJ25				DJ10	DJ11				
AJ37	CJ97	BJ97	AJ97	DJ13	DJ14				
AJ38				DJ16	DJ17		AJ57	AJ58	AJ59
AJ39	CJ99	BJ99	AJ99	DJ19	DJ20				
AJ34				DJ22	DJ23				
AJ35	CJ95	BJ95	AJ95	DJ25	DJ26		AJ60	AJ61	AJ62
AJ36	CJ96	BJ96	AJ96	DJ28	DJ29		AJ63	AJ64	AJ65
AJ40									
AJ45				DJ34	DJ35				
AJ46	CJ92	BJ92	AJ92	DJ37	DJ38				
AJ50	CJ90	BJ90	AJ90	DJ40	DJ41		AJ66	AJ67	AJ68
AJ42				DJ43	DJ44		AJ69	AJ70	AJ71
AJ49				DJ46	DJ47				
AJ41				DJ49	DJ50				
AJ26				DJ52	DJ53		AJ72	AJ73	AJ74
AJ33				DJ55	DJ56				
AJ28	CJ98	BJ98	AJ98	DJ58	DJ59				
AJ47				DJ61	DJ62				
AJ27	CJ94	BJ94	AJ94	DJ64	DJ65		AJ75	AJ76	AJ77

* NJR 1 bianco 9,85x9,85 su rete / on net

* NJR 11 panna 9,85x9,85 su rete / on net

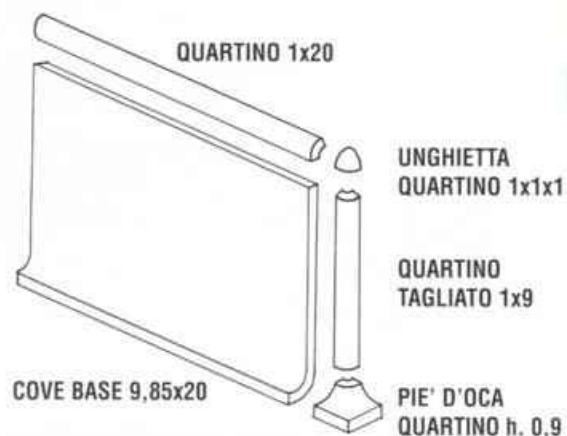

MONOCOTTURA ANTISLIP FINITURE PER INTERNI IN BICOTTURA TRADIZIONALE

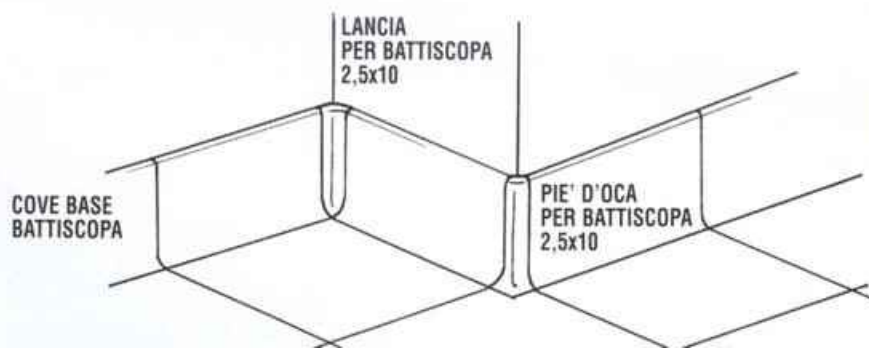

CAPITELLO 4x9,85
SPIGOLO CAPITELLO 4x1,5
QUARTINO 1x20



Inserimenti modulari su fondo J330 bianco

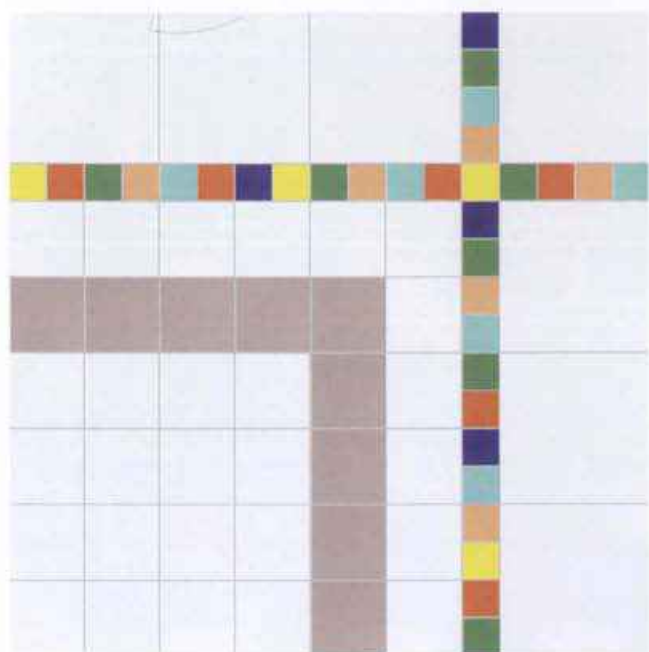

Pannello 13 J130 J137 J330

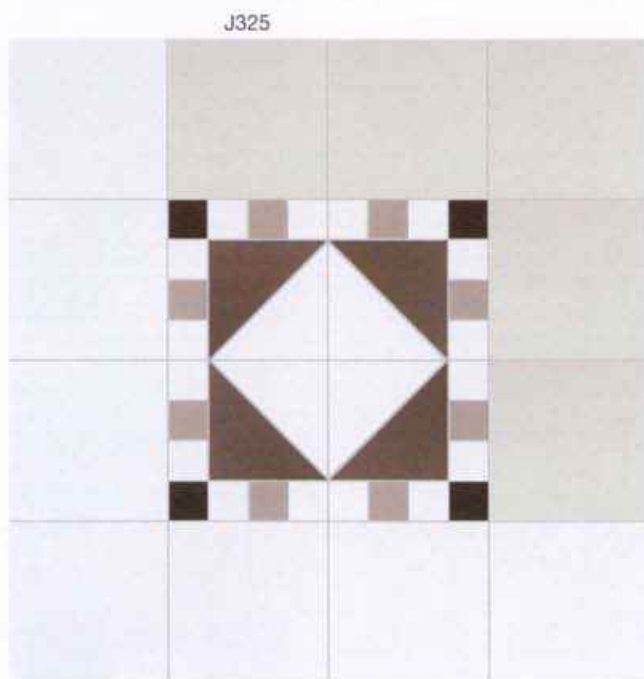

Pannello 14 - J330 - JZ30 - JZ37 - JZ39

J325

Laccati	Perle	Sardinia	Stucchi	Sorrento
<p>Bianco 20x20 - A110 9.85x9.85 - 19105 4.85x4.85 - 2106</p> <p>Avorio 20x20 - A390 9.85x9.85 - 19168 4.85x4.85 - 2108</p> <p>Almond 20x20 - A490 9.85x9.85 - 19172 4.85x4.85 - 2172</p> <p>Grigio chiaro 20x20 - A430 9.85x9.85 - 19162 4.85x4.85 - 2162</p> <p>Grigio medio 20x20 - A350 9.85x9.85 - 19126 4.85x4.85 - 2126</p> <p>Grigio scuro 20x20 - A850 9.85x9.85 - 19173 4.85x4.85 - 2173</p> <p>Grigio Antracite 20x20 - A880 9.85x9.85 - 19174 4.85x4.85 - 2174</p> <p>Neiro 20x20 - A390 9.85x9.85 - 19148 4.85x4.85 - 2148</p> <p>Rosa chiaro 20x20 - D240 9.85x9.85 - 19179 4.85x4.85 - 2179</p> <p>Rosa medio 20x20 - A010 9.85x9.85 - 19180 4.85x4.85 - 2180</p> <p>Rosa scuro 20x20 - A020 9.85x9.85 - 19181 4.85x4.85 - 2181</p> <p>Lilla chiaro 20x20 - D250 9.85x9.85 - 19182 4.85x4.85 - 2182</p> <p>Lilla medio 20x20 - D260 9.85x9.85 - 19183 4.85x4.85 - 2183</p> <p>Lilla scuro 20x20 - D270 9.85x9.85 - 19184 4.85x4.85 - 2184</p> <p>Ciclaminio chiaro 20x20 - D220 9.85x9.85 - 19176 4.85x4.85 - 2176</p> <p>Ciclaminio medio 20x20 - A080 9.85x9.85 - 19176 4.85x4.85 - 2176</p> <p>Ciclaminio scuro 20x20 - D220 9.85x9.85 - 19177 4.85x4.85 - 2177</p>	<p>Bianco 20x20 - A110 9.85x9.85 - 1130 4.85x4.85 - 1720</p> <p>Panna 20x20 - A320 9.85x9.85 - 1129 4.85x4.85 - 1725</p> <p>Grigio chiaro 20x20 - A325 9.85x9.85 - 1125 4.85x4.85 - 1725</p> <p>Grigio medio 20x20 - A337 9.85x9.85 - 1137 4.85x4.85 - 1737</p> <p>Grigio scuro 20x20 - A338 9.85x9.85 - 1138 4.85x4.85 - 1738</p> <p>Grigio Antracite 20x20 - A336 9.85x9.85 - 1136 4.85x4.85 - 1736</p> <p>Rosa antico 20x20 - A341 9.85x9.85 - 1141 4.85x4.85 - 1741</p> <p>Lampone 20x20 - A326 9.85x9.85 - 1126 4.85x4.85 - 1726</p> <p>Bianco 20x20 - A100 9.85x9.85 - 1130 4.85x4.85 - 1730</p> <p>Grigio chiaro 20x20 - A328 9.85x9.85 - 1128 4.85x4.85 - 1728</p> <p>Grigio medio 20x20 - A325 9.85x9.85 - 1125 4.85x4.85 - 1725</p> <p>Grigio scuro 20x20 - A337 9.85x9.85 - 1137 4.85x4.85 - 1737</p>	<p>Bianco spuma 20x20 - A1020 10x10 - 11020 5x5 - 21020</p> <p>Beige sabbia 20x20 - A1150 10x10 - 11150 5x5 - 21150</p> <p>Grigio perla 20x20 - A1110 10x10 - 11110 5x5 - 21110</p> <p>Grigio conchiglia 20x20 - A1120 10x10 - 11120 5x5 - 21120</p> <p>Bianco spuma 20x20 - A1020 10x10 - 11020 5x5 - 21020</p> <p>Bianco spuma 20x20 - A1020 10x10 - 11020 5x5 - 21020</p> <p>Bianco spuma 20x20 - A1020 10x10 - 11020 5x5 - 21020</p>	<p>Bianco 20x20 - J1151 9.85x9.85 - 11151 4.85x4.85 - 17151</p> <p>Avorio 20x20 - J1362 9.85x9.85 - 11152 4.85x4.85 - 17152</p> <p>Grigio chiaro 20x20 - J1363 9.85x9.85 - 11153 4.85x4.85 - 17153</p> <p>Antracite 20x20 - J1354 9.85x9.85 - 11154 4.85x4.85 - 17154</p> <p>Rosa pompeliano 20x20 - J1361 9.85x9.85 - 11161 4.85x4.85 - 17161</p> <p>Bianco 20x20 - J1365 9.85x9.85 - 11155 4.85x4.85 - 17155</p> <p>Grigio chiaro 20x20 - J1364 9.85x9.85 - 11154 4.85x4.85 - 17154</p> <p>Bianco 20x20 - J1365 9.85x9.85 - 11155 4.85x4.85 - 17155</p>	<p>Bianco 20x20 - D670 9.85x9.85 - 1670 4.85x4.85 - 2670</p> <p>Beige chiaro 20x20 - D671 9.85x9.85 - 1671 4.85x4.85 - 2671</p> <p>Grigio chiaro 20x20 - D676 9.85x9.85 - 1676 4.85x4.85 - 2676</p> <p>Grigio scuro 20x20 - D677 9.85x9.85 - 1677 4.85x4.85 - 2677</p> <p>Grigio scuro 20x20 - D677 9.85x9.85 - 1677 4.85x4.85 - 2677</p> <p>Rosa chiaro 20x20 - D672 9.85x9.85 - 1672 4.85x4.85 - 2672</p> <p>Rosa scuro 20x20 - D673 9.85x9.85 - 1673 4.85x4.85 - 2673</p> <p>Viola chiaro 20x20 - D684 9.85x9.85 - 1684 4.85x4.85 - 2684</p> <p>Viola scuro 20x20 - D685 9.85x9.85 - 1685 4.85x4.85 - 2685</p> <p>Bianco 20x20 - D670 9.85x9.85 - 1670 4.85x4.85 - 2670</p> <p>Grigio chiaro 20x20 - D676 9.85x9.85 - 1676 4.85x4.85 - 2676</p>

5 TIPOLOGIE:

COLORI BRILLANTI, CRISTALLINE CRAQUELÉ, MONOCOTTURE SATINATE E PERLINATE. COLORI PERFETTAMENTE ABBINABILI TRA LORO CHE PERMETTONO DI RISOLVERE BRILLANTEMENTE LE RICHIESTE TECNICHE ED ESTETICHE NEL TUO AMBIENTE

The image displays a comprehensive color palette organized into a grid. Each color is represented by a square swatch, often accompanied by a smaller, darker or lighter version to show its range. The colors are labeled with names in Italian and their corresponding technical codes. The labels are arranged in columns and rows, providing a systematic overview of the available color options.

Color Labels and Codes:

- Bleu chiaro:** 20x20 - 1362, 9.85x9.85 - 1667, 4.85x4.85 - 2682
- Bleu scuro:** 20x20 - 1663, 9.85x9.85 - 1663, 4.85x4.85 - 2683
- Azzurro chiaro:** 20x20 - 1680, 9.85x9.85 - 1680, 4.85x4.85 - 2680
- Azzurro scuro:** 20x20 - 1681, 9.85x9.85 - 1681, 4.85x4.85 - 2681
- Acquamarina chiaro:** 20x20 - 1678, 9.85x9.85 - 1678, 4.85x4.85 - 2678
- Acquamarina scuro:** 20x20 - 1679, 9.85x9.85 - 1679, 4.85x4.85 - 2679
- Verde chiaro:** 20x20 - 1666, 9.85x9.85 - 1666, 4.85x4.85 - 2666
- Verde scuro:** 20x20 - 1667, 9.85x9.85 - 1667, 4.85x4.85 - 2667
- Beige chiaro:** 20x20 - 1671, 9.85x9.85 - 1671, 4.85x4.85 - 2671
- Giallo scuro:** 20x20 - 1669, 9.85x9.85 - 1669, 4.85x4.85 - 2669
- Pesca chiaro:** 20x20 - 1674, 9.85x9.85 - 1674, 4.85x4.85 - 2674
- Pesca scuro:** 20x20 - 1675, 9.85x9.85 - 1675, 4.85x4.85 - 2675
- Giallo chiaro:** 20x20 - 1668, 9.85x9.85 - 1668, 4.85x4.85 - 2668
- Giallo scuro:** 20x20 - 1669, 9.85x9.85 - 1669, 4.85x4.85 - 2669
- Bianco:** 20x20 - 1670, 9.85x9.85 - 1670, 4.85x4.85 - 2670
- Bleu chiaro:** 20x20 - 1361, 9.85x9.85 - 1167, 4.85x4.85 - 2167
- Bleu scuro:** 20x20 - 1361, 9.85x9.85 - 1167, 4.85x4.85 - 2167
- Azzurro:** 20x20 - 1156, 9.85x9.85 - 1156, 4.85x4.85 - 2156
- Acquamarina chiaro:** 20x20 - 1156, 9.85x9.85 - 1166, 4.85x4.85 - 2166
- Acquamarina scuro:** 20x20 - 1155, 9.85x9.85 - 1155, 4.85x4.85 - 2155
- Verde chiaro:** 20x20 - 1156, 9.85x9.85 - 1166, 4.85x4.85 - 2166
- Verde scuro:** 20x20 - 1155, 9.85x9.85 - 1155, 4.85x4.85 - 2155
- Verde pompelino:** 20x20 - 1159, 9.85x9.85 - 1159, 4.85x4.85 - 2159
- Avorio:** 20x20 - 1162, 9.85x9.85 - 1162, 4.85x4.85 - 2162
- Noce:** 20x20 - 1164, 9.85x9.85 - 1164, 4.85x4.85 - 2164
- Rosa antico:** 20x20 - 1160, 9.85x9.85 - 1160, 4.85x4.85 - 2160
- Rosa pompelino:** 20x20 - 1161, 9.85x9.85 - 1161, 4.85x4.85 - 2161
- Pesca:** 20x20 - 1162, 9.85x9.85 - 1162, 4.85x4.85 - 2162
- Giallo reale:** 20x20 - 1160, 9.85x9.85 - 1160, 4.85x4.85 - 2160
- Giallo limone:** 20x20 - 1162, 9.85x9.85 - 1162, 4.85x4.85 - 2162
- Bianco:** 20x20 - 1151, 9.85x9.85 - 1151, 4.85x4.85 - 2151
- Caldo:** 20x20 - 1153, 9.85x9.85 - 1153, 4.85x4.85 - 2153
- Bleu chiaro:** 20x20 - A1070, 10x10 - 11070, 5x5 - 21070
- Bleu scuro:** 20x20 - A1080, 10x10 - 11080, 5x5 - 21080
- Celeste:** 20x20 - A1060, 10x10 - 11060, 5x5 - 21060
- Azzurro scuro:** 20x20 - A1060, 10x10 - 11060, 5x5 - 21060
- Acquamarina:** 20x20 - A1090, 10x10 - 11090, 5x5 - 21090
- Lurichese:** 20x20 - A1090, 10x10 - 11090, 5x5 - 21090
- Verde mare:** 20x20 - A1090, 10x10 - 11090, 5x5 - 21090
- Verde smeraldo:** 20x20 - A1100, 10x10 - 11100, 5x5 - 21100
- Beige sabbia:** 20x20 - A1150, 10x10 - 11150, 5x5 - 21150
- Duna:** 20x20 - A1160, 10x10 - 11160, 5x5 - 21160
- Rosa salmone:** 20x20 - A1130, 10x10 - 11130, 5x5 - 21130
- Rosa corallo:** 20x20 - A1140, 10x10 - 11140, 5x5 - 21140
- Bianco spuma:** 20x20 - A1000, 10x10 - 11000, 5x5 - 21000
- Bianco riflesso:** 20x20 - A1010, 10x10 - 11010, 5x5 - 21010
- Caldo cerato:** 20x20 - A1170, 10x10 - 11170, 5x5 - 21170
- Bleu elettrico:** 20x20 - J146, 9.85x9.85 - 1246, 4.85x4.85 - 2246
- Bleu notte:** 20x20 - J152, 9.85x9.85 - 1252, 4.85x4.85 - 2252
- Azzurro:** 20x20 - J140, 9.85x9.85 - 1240, 4.85x4.85 - 2240
- Celeste:** 20x20 - J145, 9.85x9.85 - 1245, 4.85x4.85 - 2245
- Acquamarina:** 20x20 - J134, 9.85x9.85 - 1234, 4.85x4.85 - 2234
- Lurichese:** 20x20 - J135, 9.85x9.85 - 1235, 4.85x4.85 - 2235
- Petralia:** 20x20 - J136, 9.85x9.85 - 1236, 4.85x4.85 - 2236
- Verde prato:** 20x20 - J142, 9.85x9.85 - 1242, 4.85x4.85 - 2242
- Verde menta:** 20x20 - J149, 9.85x9.85 - 1249, 4.85x4.85 - 2249
- Beige:** 20x20 - J133, 9.85x9.85 - 1233, 4.85x4.85 - 2233
- Rosa pesca:** 20x20 - J131, 9.85x9.85 - 1231, 4.85x4.85 - 2231
- Giallo limone:** 20x20 - J129, 9.85x9.85 - 1229, 4.85x4.85 - 2229
- Terracotta:** 20x20 - J127, 9.85x9.85 - 1227, 4.85x4.85 - 2227
- Caldo:** 20x20 - J127, 9.85x9.85 - 1227, 4.85x4.85 - 2227
- Bleu chiaro:** 20x20 - L410, 9.85x9.85 - 1514, 4.85x4.85 - 2514
- Bleu medio:** 20x20 - L420, 9.85x9.85 - 1524, 4.85x4.85 - 2524
- Bleu scuro:** 20x20 - L430, 9.85x9.85 - 1534, 4.85x4.85 - 2534
- Azzurro chiaro:** 20x20 - L560, 9.85x9.85 - 1618, 4.85x4.85 - 2618
- Azzurro medio:** 20x20 - L570, 9.85x9.85 - 1628, 4.85x4.85 - 2628
- Azzurro scuro:** 20x20 - L580, 9.85x9.85 - 1638, 4.85x4.85 - 2638
- Acquamarina chiaro:** 20x20 - L550, 9.85x9.85 - 1608, 4.85x4.85 - 2608
- Acquamarina medio:** 20x20 - L560, 9.85x9.85 - 1618, 4.85x4.85 - 2618
- Acquamarina scuro:** 20x20 - L570, 9.85x9.85 - 1628, 4.85x4.85 - 2628
- Verde chiaro:** 20x20 - L590, 9.85x9.85 - 1638, 4.85x4.85 - 2638
- Verde medio:** 20x20 - L600, 9.85x9.85 - 1648, 4.85x4.85 - 2648
- Verde scuro:** 20x20 - L610, 9.85x9.85 - 1658, 4.85x4.85 - 2658
- Beige chiaro:** 20x20 - L690, 9.85x9.85 - 1716, 4.85x4.85 - 2716
- Beige medio:** 20x20 - L700, 9.85x9.85 - 1726, 4.85x4.85 - 2726
- Beige scuro:** 20x20 - L710, 9.85x9.85 - 1736, 4.85x4.85 - 2736
- Pesca chiaro:** 20x20 - L660, 9.85x9.85 - 1696, 4.85x4.85 - 2696
- Pesca medio:** 20x20 - L670, 9.85x9.85 - 1706, 4.85x4.85 - 2706
- Pesca scuro:** 20x20 - L680, 9.85x9.85 - 1716, 4.85x4.85 - 2716
- Giallo chiaro:** 20x20 - L690, 9.85x9.85 - 1716, 4.85x4.85 - 2716
- Giallo medio:** 20x20 - L700, 9.85x9.85 - 1726, 4.85x4.85 - 2726
- Giallo scuro:** 20x20 - L710, 9.85x9.85 - 1736, 4.85x4.85 - 2736
- Arancio selenio:** 20x20 - L590, 9.85x9.85 - 1696, 4.85x4.85 - 2696
- Rosso selenio:** 20x20 - L600, 9.85x9.85 - 1706, 4.85x4.85 - 2706
- Caldo cerato:** 20x20 - L610, 9.85x9.85 - 1716, 4.85x4.85 - 2716

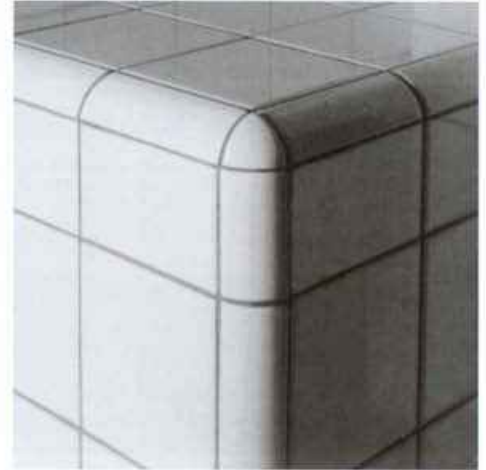
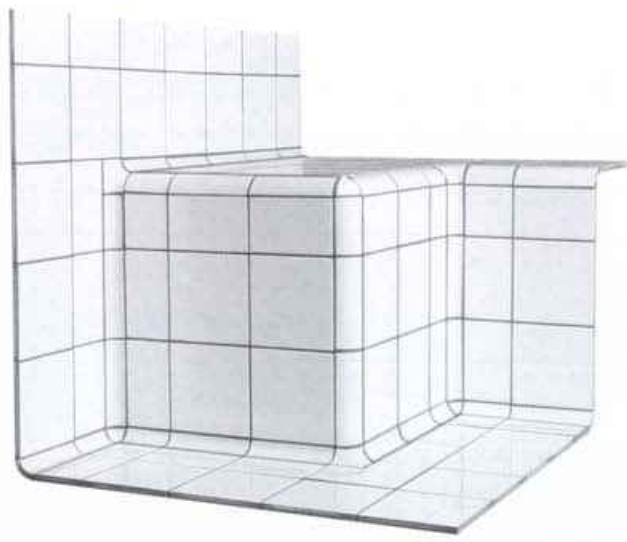

PEZZI SPECIALI
TRIMS AND FITTINGS



SISTEMI DI MONTAGGIO
METHOD OF FIXING

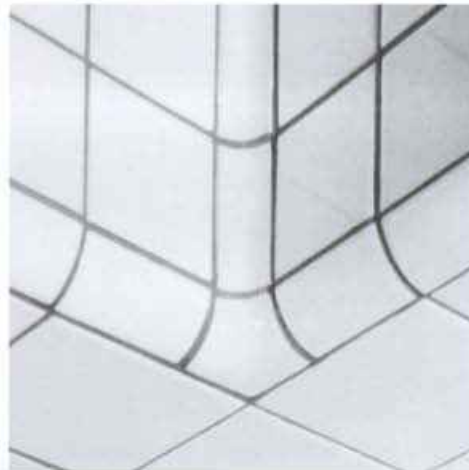

Le Perle

monocottura modul system



Institute Kurrenk & Wein
Dr. Michael Schwein
Ehrhardstrasse 19
D-81825 München
Tel.: (089) 42 72 16-48
Fax: (089) 42 72 16-58



PRÜFBERICHT

Nr. 2192/98 vom 27.10.1998

Bestimmung der rutschhemmenden Eigenschaft nach DIN 51 097
Naßbelastete Barfußbereiche

Auftraggeber:	Senio s.r.l., Via Tarroni, 1, I-48012 Bagnacavallo (RA)
Auftragsdatum:	08.10.1998
Probenahme:	Auftraggeber
Prüfgegenstand:	Steinzeugfliesen glasiert, Serie "Le Perle", JR01 Bianco, Format 10x10 cm, 1. Sorte
Produktname:	DIN EN 170 B1
Eingang des Prüfgegenstands:	12.10.1998
Probennummer:	98/277
Auftragsnummer:	75 2152 25
Fugenbreite des geprüften Bodenbelages:	3 mm
Prüfdatum:	27.10.1998

PRÜFERGEBNIS

- | | | |
|----|--------------------------|-------|
| 1. | Mittlerer Neigungswinkel | 18° |
| 2. | Besturfskategorie | A + B |



Seite 1 von 1 Seite

Die Probenuntersuchung beschränkt sich ausschließlich auf die angegebenen Prüfverfahren. Die Prüfergebnisse sind für die vorgelagerten spezifischen Zwecke.
Una garanzia ova assicurazione dell'indagine, limitata a questi scopi specifici, non è fornita.

08/10 '00 REC 14/41 FAX 09 02 030048

CENTRO CERAMICO
CENTRO DI RICERCA E SPERIMENTAZIONE PER L'INDUSTRIA CERAMICA

SEDE
Via Martini, 26 - 40138 Bologna
Tel. (051) 204016 - Fax: (051) 200065

CERTI.CER.
LABORATORIO DI ZONA
Via Varesi d'Adda, 1 - 41046 SERRAVALLE
Tel. e Fax: (0536) 802104
Fax: (IVA 0094778-0375)

Bologna, 25/10/00

Spett.le
SENIO ALTA CERAMICA FAENTINA S.r.l.
Via Tarroni, 1
48012 BAGNACAVALLLO (RA)

SEZIONE CERAMICI INDUSTRIALI
RAPPORTO DI PROVA N° 3822/00
su piastrelle di ceramica secondo UNI EN 87

Richiesto da:	SENIO ALTA CERAMICA FAENTINA S.F.L. VIA TARRONI, 1 48012 BAGNACAVALLLO (RA)
in data:	22/09/00
Per il prodotto contrassegnato:	"JRL6"

RISULTATI

TOTAL CORNER OF ACCEPTANCE - MEDIUM VALUE
Angolo totale di accettazione - valore medio:
Volume di compressione (cm³/dm²):

18°

CLASSIFICAZIONE (ZH 1/571 - ED. LUGLIO 1993)
GROUP OF ANTI-SLIP RESISTANCE
Gruppo di resistenza allo scivolamento:
Gruppo relativo al volume della compressione:

R10

Mod. DIN 5130-R 26/098

Prof.

Le Perle modul system

TEST DI LABORATORIO/DATI TECNICI
LINEA LE PERLE MONOCOTTURA
Le prove tecniche sono state eseguite in base alle norme europee CEN.

QUALITY REPORT/LABORATORY TESTS
SINGLE FIRED LE PERLE LINE
*The technological test have been performed according to the CEN
(European committee for standardization) standards
and the results are provided below.*

COLOUR	EN 122	EN 154	EN 105	EN 104
	acid resistance	P.E.I. rating	crazing resistance	thermal shock
BIANCO	AA	4	YES	YES
GRIGIO CHIARO	AA	4	YES	YES
GRIGIO MEDIO	A	3	YES	YES
GRIGIO SCURO	AA	3	YES	YES
GRIGIO ANTRACITE	A	3	YES	YES
BEIGE	AA	4	YES	YES
PANNA	A	4	YES	YES
ACQUAMARINA	AA	3	YES	YES
TURCHESE	A	3	YES	YES
PETROLIO	A	3	YES	YES
AZZURRO	AA	3	YES	YES
CELESTE	AA	3	YES	YES
BLEU ELETTRICO	A	3	YES	YES
BLEU NOTTE	A	3	YES	YES
VERDE PRATO	AA	4	YES	YES
VERDE MENTA	A	3	YES	YES
ROSA ANTICO	AA	3	YES	YES
LAMPONE	A	3	YES	YES
ROSA PESCA	AA	4	YES	YES
GIALLO LIMONE	A	3	YES	YES
TERRACOTTA	A	3	YES	YES
COTTO	A	3	YES	YES

Leggere differenze di tonalità e di effetto rientreranno nelle caratteristiche di lavorazione del prodotto ceramico.

Slight differences of shade and effect are typical of the ceramic work.

De légères différences de nuance et d'effet font partie des caractéristiques de production des carreaux.

Leichte Unterschiede von Nuance und chromatischem Effekt sind typische Merkmale der Produktionsverfahren des keramischen Produkts.



Alta Ceramica Faentina
SENIO srl

Via Tarroni, 1 • 48012 • BAGNACAVALLO (Ra) • ITALY

Tel. 0545/935811 • Internet: www.seniocer.it

Uff. Comm. Italia: Fax 0545/64333 • e-mail: info@seniocer.it

Esterio Exp. Dept.: Fax 0545/64313 • e-mail: export@seniocer.it